



Service Hotline and Official Website

☎ 0512-57951586 🌐 <http://www.ronyiks.com>

总部

昆山荣逸自动化设备有限公司
📍 江苏省苏州市昆山市千灯镇石浦宏川路5号-4栋

深圳子公司

深圳市荣逸自动化科技有限公司
📍 深圳市龙华区大浪街道国乐科技园6栋401



官网



公众号

RONYI 荣逸

2010

技术兴起
The rise of technology

2026

助力企业打造自己的拧紧生态
Empower enterprises to build their own tightening ecosystem



一站式解决打螺丝难题

ONE-STOP SCREW FASTENING SOLUTION PROVIDE

2026

CONTENTS

目录

01 企业篇 Corporate Section

- P04-07 公司简介
- P08-09 战略布局

02 人工站 Manual Station

- P10-13 手工作业
- P14-35 供钉机
- P36-39 智能电批
- P40-41 附件

03 机用站 Machine-mounted Station

- P42-47 机用工位
- P48-63 供钉机
- P64-65 补料仓

04 伙伴篇 Partner Section

- P66-67 合作伙伴



数据顺达全球 及时应您所需

荣逸全周期闭环服务·从选型到运维全程无忧! 1对1定制方案, 上门勘测产线, 精准匹配工况

800 + 建立合作关系
50 + 专业研发团队
30 + 售后服务团队
24 h 售后在线时间
34 ↑ 省级行政区域
14 + 产品畅销国家

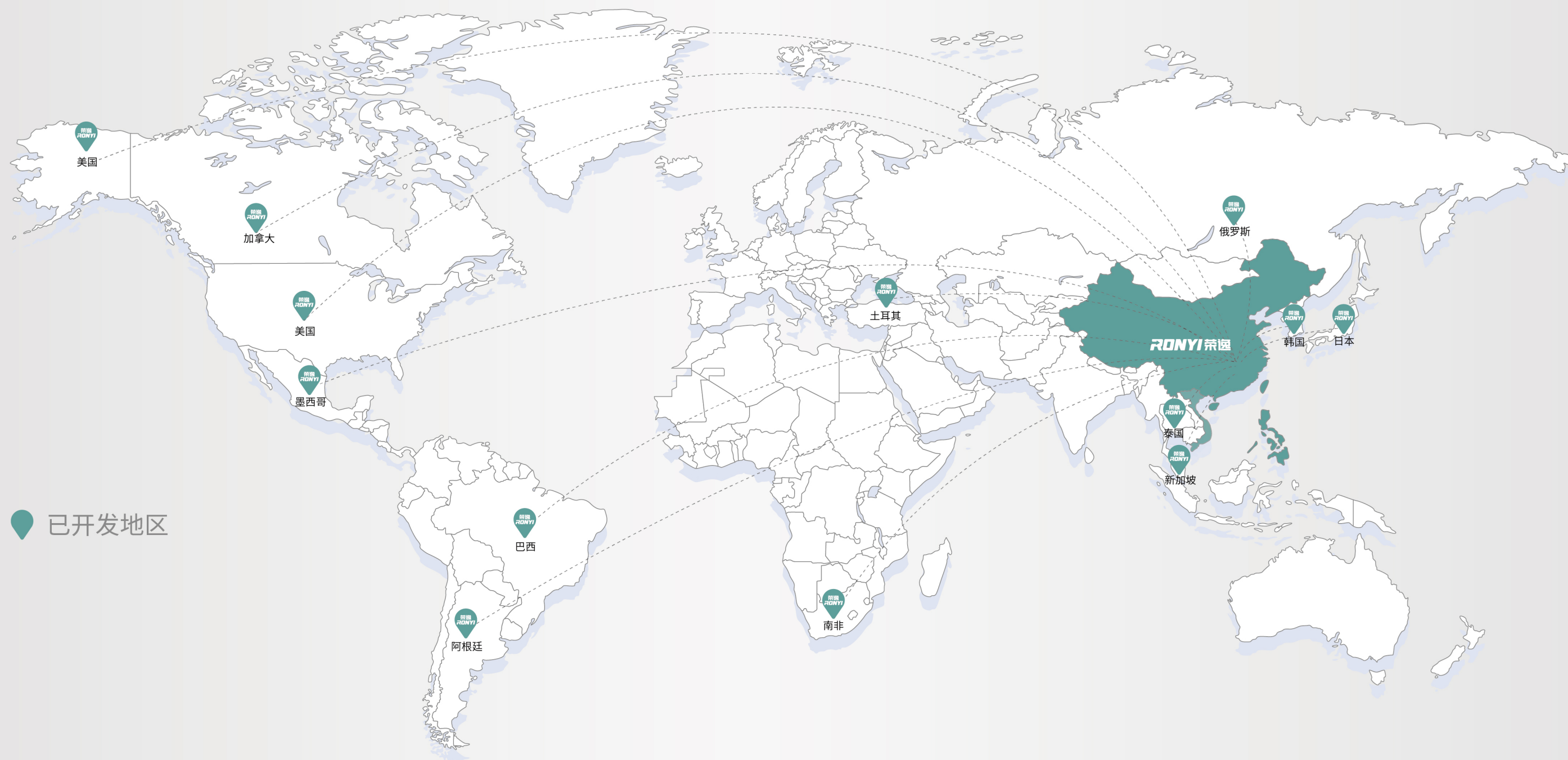



荣逸智能拧紧
每一步都精准



智能人工站 助力企业打造自己的拧紧生态

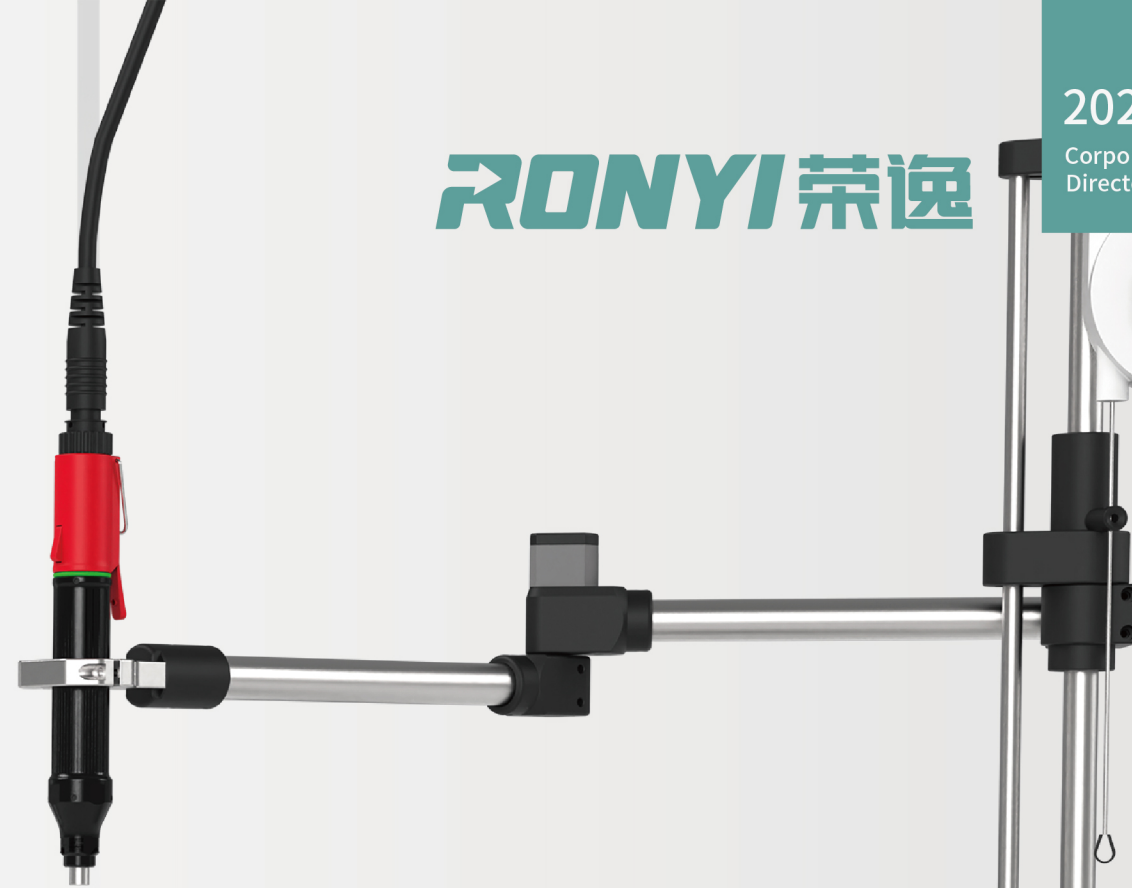
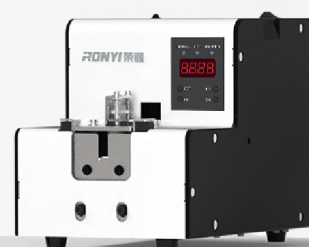

INTELLIGENT MANUAL STATION

Smart Start



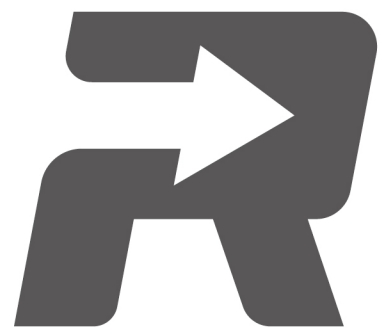

MANUAL STATION SERIES

人工站系列

人工站系列产品:转盘手挖式、手持吹气式、手持智能电批、支架力臂
MANUAL STATION SERIES: TURNTABLE MANUAL FEEDING TYPE, HANDHELD PNEUMATIC BLOWING TYPE, HANDHELD INTELLIGENT ELECTRIC SCREWDRIVER, SUPPORT ARM

TURNTABLE MANUAL PICK SCREW FEEDER 转盘式手挖供钉机



QHW-328



QHW-528

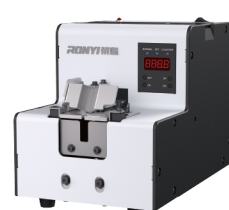

QHW-301S



QHW-221

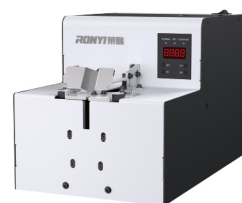

QHW-728



QHW-160

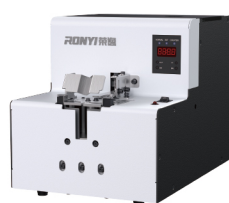

QHW-190

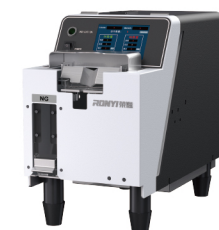

QHW-160FD



QHW-190FD

COUNTING TYPE SCREW FEEDER 点数式供钉机



QSW-221



QSW-728



QSW-190



QSW-160FD

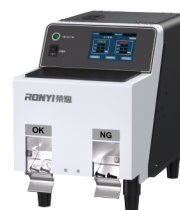

QSW-190FD



QST-220FD



QST-350FD



QST-200



QST-300



QST-350

HANDHELD AIR BLOWING SERIES 手持式吹气供钉机



QDW-120



QDW-190FD



QDT-200



QDT-300



QDT-350



转盘式手挖供钉机

Turntable Manual Pick Screw Feeder

手动取料、自动分料计数的 螺丝锁付防呆核心设备

-  卡钉率低
-  稳定性高
-  操作便捷
-  精度准确



Help enterprises build their own
tightening ecosystem.



产品详情 Product Details



QHW-328

转盘式手挖供钉机

尺寸:长:160 宽:82 高:118mm

(不支持含垫片螺丝)

重量:N.W 1.53KG



平头螺丝



圆头螺丝

帽头

帽头直径 $1.5 \leq D \leq 3$
帽头厚度 $0.3 \leq H \leq 1$

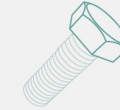

螺牙 (M1.0-M1.7) (M2.0)

螺牙径长 ≤ 5 ≤ 3
螺牙总长 < 6 < 4



范围

M1.0-M2.0

容量

50CC

通讯协议

IO

QHW-528

转盘式手挖供钉机

尺寸:长:182 宽:124 高:145mm

重量:N.W 3.1KG



平头螺丝



圆头螺丝



普通内六角螺丝



普通外六角螺丝

帽头

帽头直径 $1.5 \leq D \leq 8$
帽头厚度 $0.3 \leq H \leq 5$

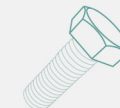

螺牙 (M1.0-M3.0) (M4.0)

螺牙径长 ≤ 12 ≤ 9
螺牙总长 < 15 < 10



范围

M1.0-M4.0

容量

220CC

通讯协议

IO



QHW-301S

转盘式手挖供钉机

尺寸:长:202 宽:126 高:150mm

重量:N.W 3.1KG



平头螺丝



圆头螺丝



普通内六角螺丝



普通外六角螺丝

帽头

帽头直径 $1.5 \leq D \leq 8$
帽头厚度 $0.3 \leq H \leq 5$

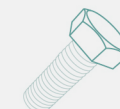

螺牙 (M2.0-M3.0) (M4.0)

螺牙径长 ≤ 12 ≤ 9
螺牙总长 < 15 < 10



范围

M2.0-M4.0

容量

220CC

通讯协议

IO

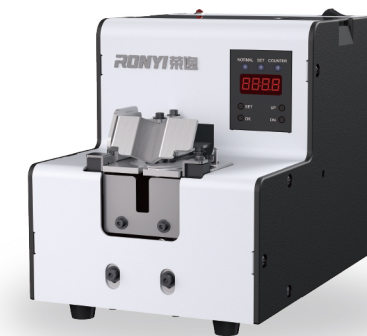

H 转盘式手挖供钉机

TURNTABLE MANUAL PICK SCREW FEEDER

MANUAL DIGGING

QHW-221 转盘式手挖供钉机

尺寸:长:182 宽:123 高:145mm
重量:N.W 3.5KG



帽头

帽头直径 $1.5 \leq D \leq 8$
帽头厚度 $0.3 \leq H \leq 5$

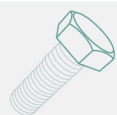

螺牙

(M1.2-M2.0) (M2.3-M4.0)

螺牙径长 ≤ 8 ≤ 6
螺牙总长 < 10 < 8



范围

M1.2-M4.0

容量

300CC

通讯协议

IO

QHW-160 转盘式手挖供钉机

尺寸:长:263 宽:162 高:178mm
重量:N.W 5KG

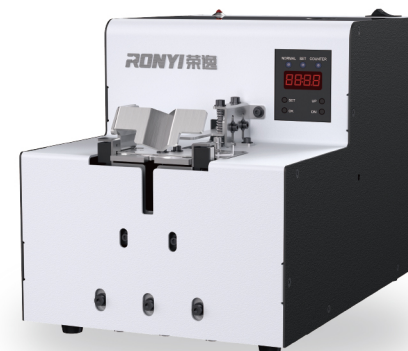

帽头

帽头直径 $3 \leq D \leq 12$
帽头厚度 $0.3 \leq H \leq 7$

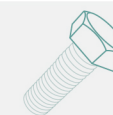

螺牙

(M2.0-M3.0) (M4.0-M5.0)

螺牙径长 ≤ 20 ≤ 15
螺牙总长 < 25 < 20



范围

M2.0-M5.0

容量

600CC

通讯协议

IO

QHW-728 转盘式手挖供钉机

尺寸:长:263 宽:162 高:178mm
重量:N.W 5KG

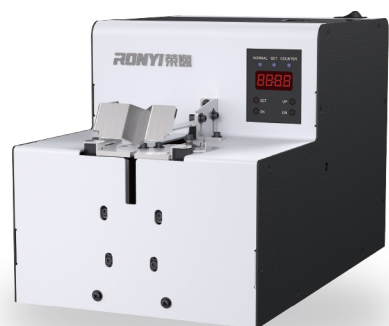

帽头

帽头直径 $3 \leq D \leq 12$
帽头厚度 $0.3 \leq H \leq 7$

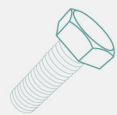

螺牙

(M2.0-M3.0) (M4.0-M5.0)

螺牙径长 ≤ 20 ≤ 15
螺牙总长 < 25 < 20



范围

M2.0-M5.0

容量

600CC

通讯协议

IO

QHW-190 转盘式手挖供钉机

尺寸:长:288 宽:190 高:213mm
重量:N.W 7KG

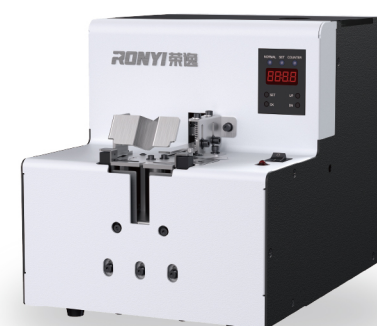

帽头

帽头直径 $3 \leq D \leq 15$
帽头厚度 $0.3 \leq H \leq 9$

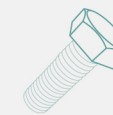

螺牙

(M2.0-M3.0) (M4.0-6.0)

螺牙径长 ≤ 25 ≤ 20
螺牙总长 < 30 < 25



范围

M2.3-M6.0

容量

900CC

通讯协议

IO



转盘式手挖供钉机

TURNTABLE MANUAL PICK SCREW FEEDER



卡钉率低



稳定性高



操作便捷



精度准确

上料 流程 Feeding Process

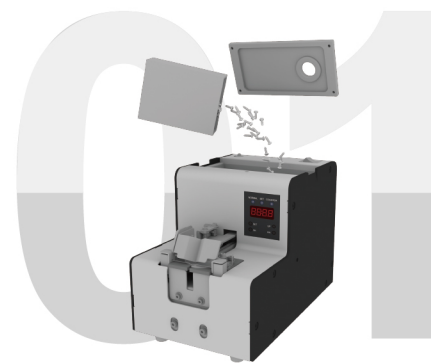

放置螺钉

取下上盖, 观察是否有异物, 将螺丝放入料槽室内, 至轨道下沿1-2mm。

QHW-160FD 转盘式手挖供钉机

尺寸:长:323 宽:163 高:279mm

重量:N.W 8KG



平头螺丝



圆头螺丝



普通内六角螺丝



普通外六角螺丝

帽头

帽头直径 $2 \leq D \leq 12$
帽头厚度 $1 \leq H \leq 7$

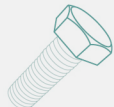

螺牙

(M2.0-M3.0) (M4.0-M5.0)

螺牙径长 ≤ 20 ≤ 15
螺牙总长 < 25 < 20



范围

M2.0-M5.0

容量

600CC

通讯协议

IO/485



分料定位

单颗有序输送至转盘取料位, 卡槽精准卡位固定螺丝, 确保取料位置统一。

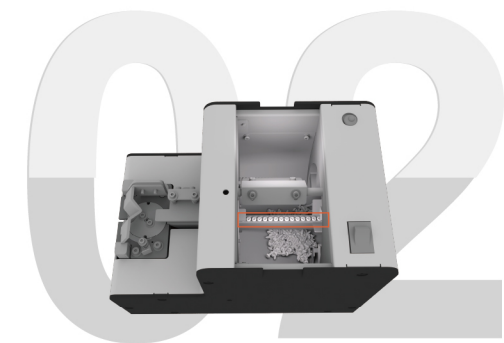

出料待取

定位后的螺丝稳定停留在取料位, 无偏移、无滑落, 处于可直接手挖取料的待作业状态。

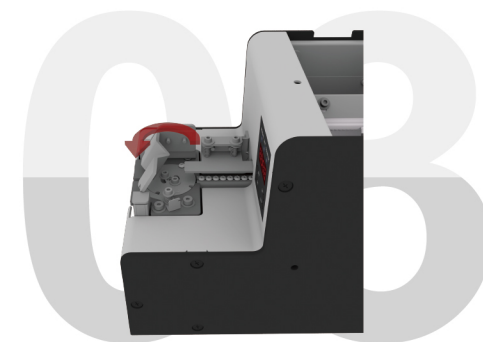

QHW-190FD 转盘式手挖供钉机

尺寸:长:323 宽:190 高:290mm

重量:N.W 9KG



平头螺丝



圆头螺丝



普通内六角螺丝



普通外六角螺丝

帽头

帽头直径 $5.5 \leq D \leq 15$
帽头厚度 $2 \leq H \leq 10$

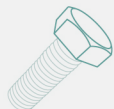

螺牙

(M3.0-M6.0)

螺牙径长 ≤ 25
螺牙总长 < 28



范围

M3.0-M6.0

容量

900CC

通讯协议

IO/485



取料锁付

电批批头对准取料位螺丝, 下压卡槽, 向前拉出螺丝即可锁付。

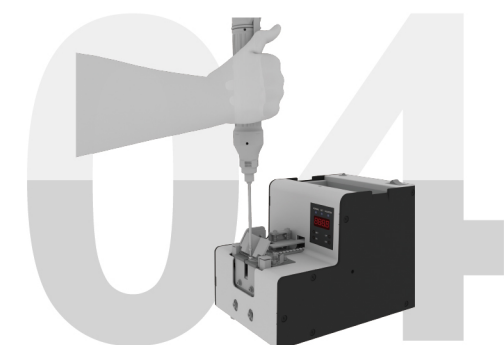

产品优势 Product Advantages

适用性广

- 适用多种螺钉尺寸
- 长径比 ≤ 1 也可适用



卡钉率低

- 筛料装置独立驱动
- 异常姿态螺钉高效筛除

0.02%

定位精准

- 十字槽轮机构驱动
- 到位后结构锁死
- 重复定位精度 ± 0.05



防呆防错

- 扫码开盖防止错误加料



故障率低

- 直流无刷电机
- 保证设备稳定运行



灵活调整

- 可视化参数设置界面
- 中文显示



高效送料

- 四分度转盘单颗分料
- 送料速度1-1.5S/颗



功能多样

- 多种扩展功能模块:
- 缺料/满料检测, 螺钉清洁等



适用机型 Applicable Models

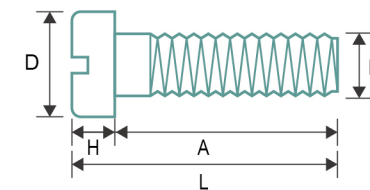

螺钉范围	料仓容量	产品型号	出料方式	电源V/Hz
M1.0-M2.0	50cc	QHW-328	转盘式	240V/50Hz
M1.0-M4.0	220cc	QHW-528		
M1.2-M4.0	300cc	QHW-221		
M2.0-M4.0	220cc	QHW-301S		
M2.0-M5.0	600cc	QHW-728		
M2.0-M5.0	600cc	QHW-160		
M2.0-M5.0	600cc	QHW-160FD		
M2.3-M6.0	900cc	QHW-190		
M3.0-M6.0	900cc	QHW-190FD		

* 上述为参考值, 实际适配螺钉规格请与我司技术支持沟通, 且超出范围的螺钉可以提供样钉进行测试

产品结构 Product Structure

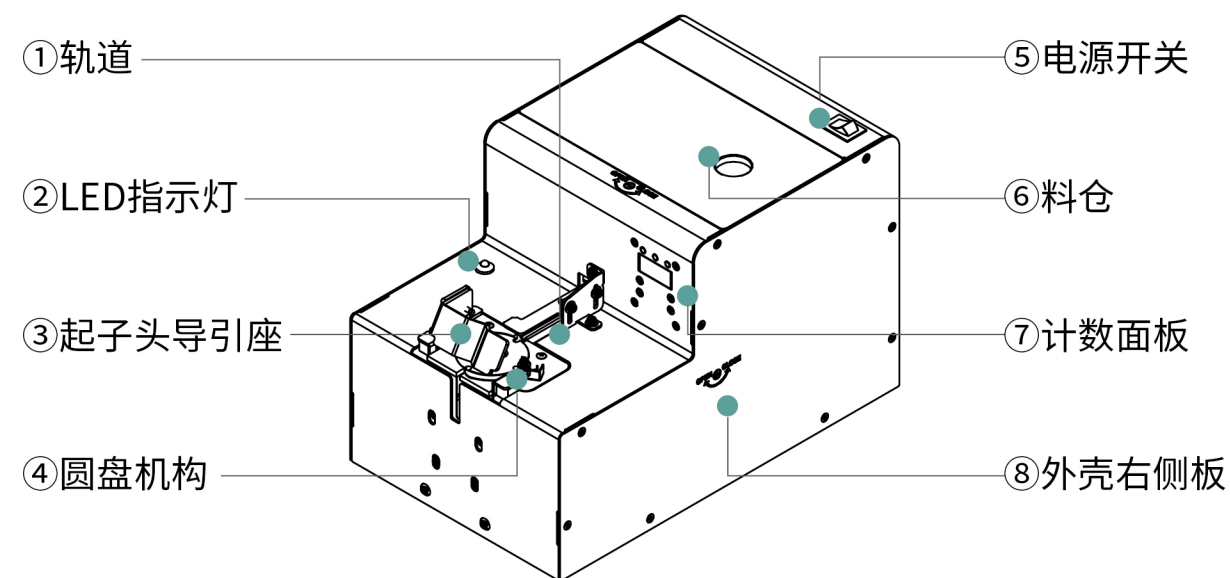

点数式供钉机

Counting Type Screw Feeder

标准化生产与库存管理的核心设备

- 卡钉率低
- 稳定性高
- 操作便捷
- 精度准确



Help enterprises build their own tightening ecosystem.

产品详情 Product Details



QSW-221

点数式手推供钉机

尺寸:长:228 宽:123 高:192mm
重量:N.W 3.5KG

- 平头螺丝
- 圆头螺丝
- 普通内六角螺丝
- 普通外六角螺丝

帽头	螺牙 (M1.7-M2.0) (M2.3-M4.0)
帽头直径 1.5≤D≤8 帽头厚度 1≤H≤5	螺牙径长 ≤8 ≤6 螺牙总长 <10 <8

范围	容量	通讯协议
M1.7-M4.0	300CC	IO



QSW-728

点数式手推供钉机

尺寸:长:263 宽:162 高:222mm
重量:N.W 5KG

- 平头螺丝
- 圆头螺丝
- 普通内六角螺丝
- 普通外六角螺丝

帽头	螺牙 (M2.0-M3.0) (M4.0-M5.0)
帽头直径 3≤D≤12 帽头厚度 0.3≤H≤7	螺牙径长 ≤20 ≤15 螺牙总长 <25 <20

范围	容量	通讯协议
M2.0-M5.0	600CC	IO



QSW-190

点数式手推供钉机

尺寸:长:345 宽:190 高:254mm
重量:N.W 7KG

- 平头螺丝
- 圆头螺丝
- 普通内六角螺丝
- 普通外六角螺丝

帽头	螺牙 (M2.0-M3.0) (M4.0-6.0)
帽头直径 3≤D≤15 帽头厚度 0.3≤H≤9	螺牙径长 ≤25 ≤20 螺牙总长 <33 <25

范围	容量	通讯协议
M2.3-M6.0	900CC	IO



S 点数式供钉机

COUNTING TYPE
SCREW FEEDER

AUTOMATIC COUNT

QSW-160FD 点数式手推供钉机

尺寸:长:355 宽:163 高:279mm

重量:N.W 8KG



帽头

帽头直径 $2 \leq D \leq 12$
帽头厚度 $1 \leq H \leq 7$

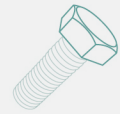

螺牙

(M2.0-M3.0) (M4.0-M5.0)

螺牙径长 ≤ 20 ≤ 15
螺牙总长 < 25 < 20



范围

M2.0-M5.0

容量

600CC

通讯协议

IO/485



QST-200FD 点数式手推供钉机

尺寸:长:475 宽:220 高:354mm

重量:N.W 20KG



帽头

帽头直径 $5.5 \leq D \leq 15$
帽头厚度 $2 \leq H \leq 10$

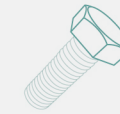

螺牙

(M3.0-M6.0)

螺牙径长 ≤ 35
螺牙总长 < 45



范围

M3.0-M6.0

容量

1000CC

通讯协议

IO/485



QSW-190FD 点数式手推供钉机

尺寸:长:355 宽:190 高:290mm

重量:N.W 9KG



帽头

帽头直径 $5.5 \leq D \leq 15$
帽头厚度 $2 \leq H \leq 10$

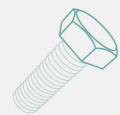

螺牙

(M3.0-M6.0)

螺牙径长 ≤ 25
螺牙总长 < 28



范围

M3.0-M6.0

容量

900CC

通讯协议

IO/485



QST-350FD 点数式手推供钉机

尺寸:长:495 宽:350 高:445mm

重量:N.W 40KG



帽头

帽头直径 $5.5 \leq D \leq 15$
帽头厚度 $2 \leq H \leq 10$

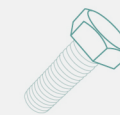

螺牙

(M3.0-M10.0)

螺牙径长 ≤ 40
螺牙总长 < 50



范围

M3.0-M10.0

容量

3000CC

通讯协议

IO/485



点数式供钉机

COUNTING TYPE SCREW FEEDER

- 卡钉率低
- 稳定性高
- 操作便捷
- 精度准确



上料 流程 Feeding Process



参数设置

设定目标出料数量(如 5 颗),
并可按需调节出料速度。

QST-200 点数式手推供钉机

尺寸:长:390 宽:200 高:352mm

重量:N.W 20KG

- 平头螺丝
- 圆头螺丝
- 普通内六角螺丝
- 普通外六角螺丝

帽头

帽头直径 $3 \leq D \leq 13$
帽头厚度 $2 \leq H \leq 9$

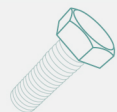

螺牙

螺牙径长 ≤ 40
螺牙总长 < 49



范围

M2.0-M6.0

容量

1000CC

通讯协议

IO/485



螺钉排列

料仓检查轨道,确保螺丝顺畅输送至
取料口,无卡料、叠料现象。



QST-350 点数式手推供钉机

尺寸:长:470 宽:350 高:445mm

重量:N.W 40KG

- 平头螺丝
- 圆头螺丝
- 普通内六角螺丝
- 普通外六角螺丝

帽头

帽头直径 $3 \leq D \leq 13$
帽头厚度 $2 \leq H \leq 10$

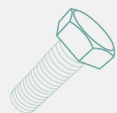

螺牙

螺牙径长 ≤ 60
螺牙总长 < 69



范围

M3.0-M10.0

容量

3000CC

通讯协议

IO/485

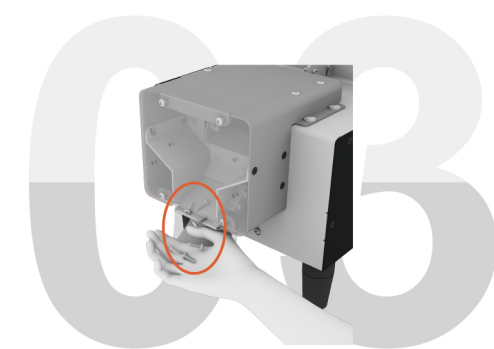

推板取料

用手按压设备的取料口,当计数达到设定
数量 5 时,送料自动停止,防止多出料。

循环作业

从取料口取出已点数的螺丝,完成
一次循环进行下一轮点数作业。

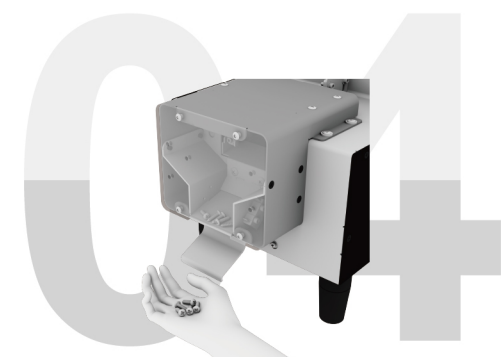

产品优势 Product Advantages

适用性广

- 适用多种螺钉尺寸
- 长径比≤1也可适用



点数精准

- 双传感器监测分料装置
- 运行状态, 点数更精准



定位精准

- 十字槽轮机构驱动
- 到位后结构锁死
- 重复定位精度±0.05



防呆防错

- 扫码开盖防止错误加料



故障率低

- 直流无刷电机
- 保证设备稳定运行



灵活调整

- 可视化参数设置界面
- 中文显示



高效送料

- 四分度转盘单颗分料
- 送料速度1-1.5S/颗



功能多样

- 多种扩展功能模块:
- 缺料/满料检测, 螺钉清洁等



适用机型 Applicable Models

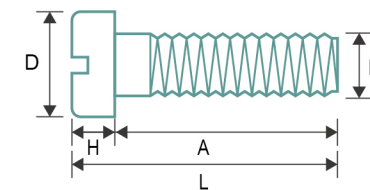

螺钉范围	料仓容量	产品型号	出料方式	电源V/Hz
M1.7-M4.0	300cc	QSW-221	转盘式	240V/50Hz
M2.0-M5.0	600cc	QSW-728		
M2.3-M6.0	900cc	QSW-190		
M2.0-M5.0	600cc	QSW-160FD		
M3.0-M6.0	900cc	QSW-190FD		
M3.0-M6.0	1000cc	QST-220FD		
M3.0-M10.0	3000cc	QST-350FD	侧拉式	240V/50Hz
M2.0-M6.0	1000cc	QST-200		
M2.0-M6.0	2000cc	QST-300		
M3.0-M10.0	3000cc	QST-350		

* 上述为参考值, 实际适配螺钉规格请与我司技术支持沟通, 且超出范围的螺钉可以提供样钉进行测试

产品结构 Product Structure

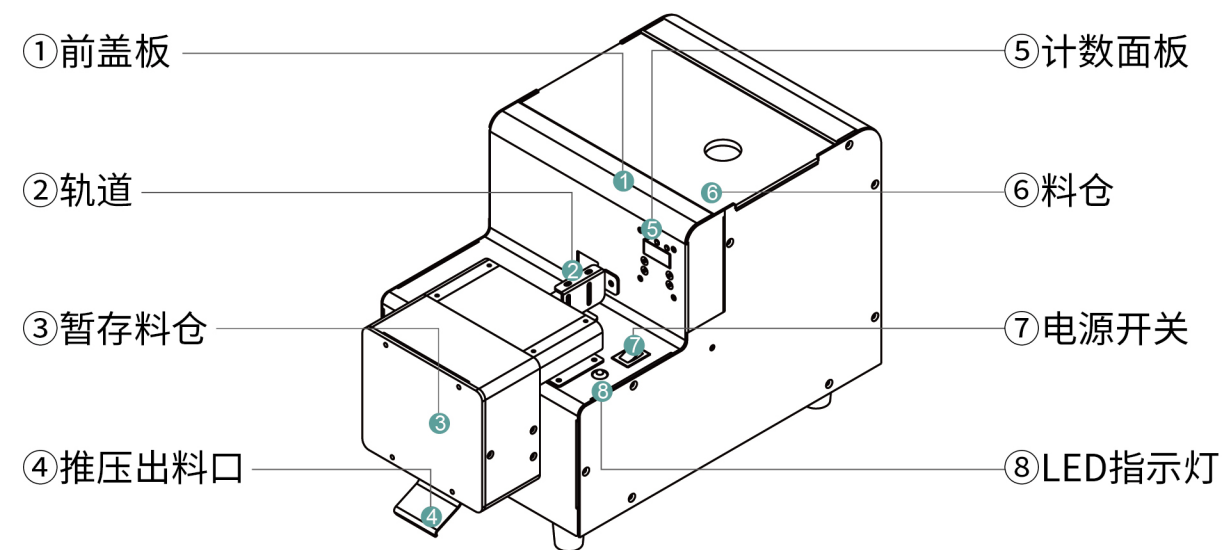

手持式吹气供钉机

Handheld Blow-type Screw Feeder

一体化气送供料, 单手锁付 稳定的核心设备

卡钉率低

稳定性高

操作便捷

精度准确



Help enterprises build their own
tightening ecosystem.

产品详情 Product Details



QDW-120

滚筒式吹气供钉机

(不支持含垫片螺丝)

尺寸:长:338 宽:124 高:240mm

重量:N.W 6KG

平头螺丝 圆头螺丝 普通内六角螺丝

帽头 帽头直径 $1.5 \leq D \leq 6$ 帽头厚度 $0.3 \leq H \leq 3$		螺牙 (M1.7-M2.0) 螺牙径长 ≤ 8 螺牙总长 < 10	
范围 M1.7-M2.0	容量 300CC	通讯协议 IO	



QDW-190FD

滚筒式吹气供钉机

(不支持含垫片螺丝)

尺寸:长:355 宽:190 高:290mm

重量:N.W 10KG

平头螺丝 圆头螺丝 普通内六角螺丝

帽头 帽头直径 $5.5 \leq D \leq 12$ 帽头厚度 $2 \leq H \leq 10$		螺牙 (M3.0-M6.0) 螺牙径长 ≤ 20 螺牙总长 < 30	
范围 M3.0-M6.0	容量 900CC	通讯协议 IO/485	



QDT-200

推举式吹气供钉机

(不支持含垫片螺丝)

尺寸:长:390 宽:200 高:352mm

重量:N.W 20KG

平头螺丝 圆头螺丝 普通内六角螺丝

帽头 帽头直径 $3 \leq D \leq 13$ 帽头厚度 $2 \leq H \leq 9$		螺牙 (M2.0-M6.0) 螺牙径长 ≤ 40 螺牙总长 < 49	
范围 M2.0-M6.0	容量 1000CC	通讯协议 IO/485	



手持式吹气供钉机

HANDHELD BLOW-TYPE SCREW FEEDER



卡钉率低



稳定性高



操作便捷



精度准确



上料 流程 Feeding Process

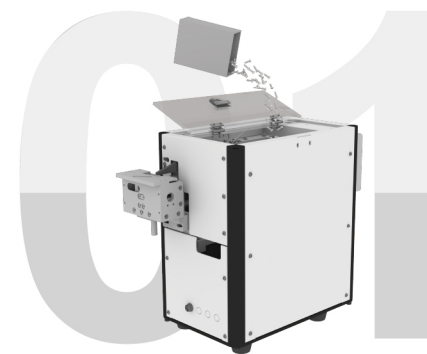

加料上料

将螺丝倒入料仓, 不超过输送轨道高度, 启动设备, 让螺丝自动排列至分料口。

QDT-300

推举式吹气供钉机

尺寸:长:390 宽:300 高:352mm

(不支持含垫片螺丝)

重量:N.W 25KG



平头螺丝



圆头螺丝



普通内六角螺丝

帽头

帽头直径 $3 \leq D \leq 13$
帽头厚度 $2 \leq H \leq 9$

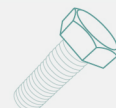

螺牙

(M2.0-M6.0)
螺牙径长 ≤ 40
螺牙总长 < 49



范围

M2.0-M6.0

容量

2000CC

通讯协议

IO/485

整序筛选

推举上料, 螺丝沿轨道单颗同向排列, 毛刷剔除不良姿态螺丝, 传感器监控料况。

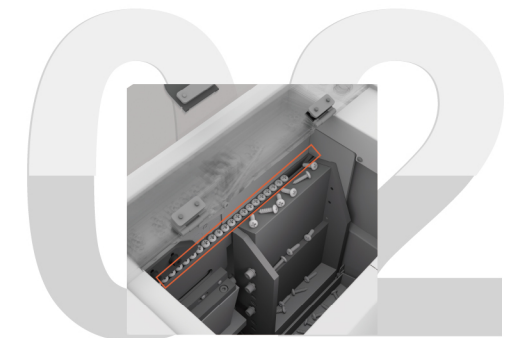

QDT-350

推举式吹气供钉机

尺寸:长:470 宽:350 高:445mm

(不支持含垫片螺丝)

重量:N.W 40KG



平头螺丝



圆头螺丝



普通内六角螺丝

帽头

帽头直径 $3 \leq D \leq 13$
帽头厚度 $2 \leq H \leq 10$

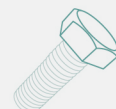

螺牙

(M3.0-M10.0)
螺牙径长 ≤ 60
螺牙总长 < 69



范围

M3.0-M10.0

容量

3000CC

通讯协议

IO/485

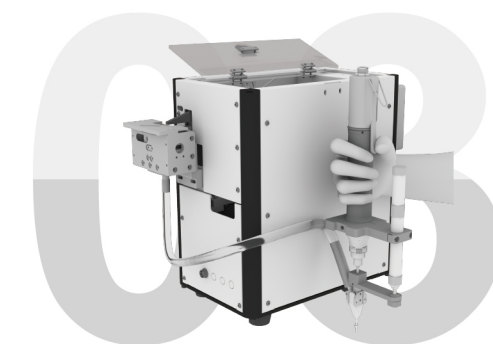

对接电批

将供钉机出嘴精准对接电批批头, 锁紧连接卡扣, 试吹 1-2 颗螺丝, 确认送料至批头位置精准。

锁付作业

批头对准锁付位置, 一键操作, 全程无需手取螺丝, 单手持机即可完成。

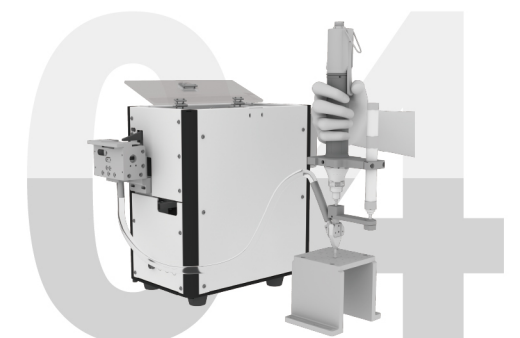

产品优势 Product Advantages

适用性广

- 适用多种螺钉尺寸
- 长径比 ≤ 1 也可适用



清洁上料

- 采用阶梯式推板上料
- 减少螺钉摩擦产生碎屑



更大容量

- 多种料仓容量
- 可供螺钉容纳



防呆防错

- 扫码开盖防止错误加料



稳定性高

- 定制话配件
- 更适配物料特性



快速复原

- 送料位置可视
- 无遮挡, 便于维护



功能多样

- 多种扩展功能模块:
- 缺料/满料检测, 螺钉清洁等



兼容电批

- 轻量化设计, 降低劳动强度
- 操作更灵活, 适配多工位

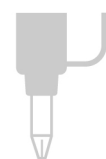

适用机型 Applicable Models

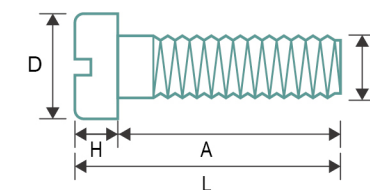

螺钉范围	料仓容量	产品型号	出料方式	电源V/Hz
M1.7-M2.0	300cc	QDW-120	吹气式	240V/50Hz
M3.0-M6.0	900cc	QDW-190FD		
M2.0-M6.0	1000cc	QDT-200		
M2.0-M6.0	2000cc	QDT-300		
M3.0-M10.0	3000cc	QDT-350		

* 上述为参考值, 实际适配螺钉规格请与我司技术支持沟通, 且超出范围的螺钉可以提供样钉进行测试

产品结构 Product Structure

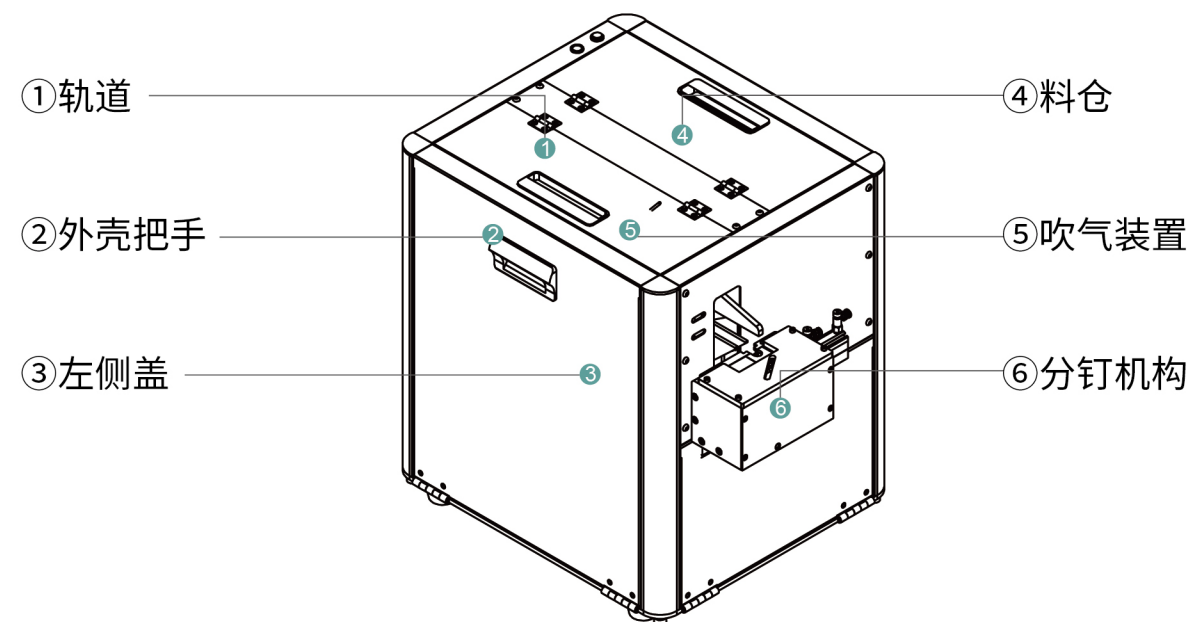

手持式智能电批

Handheld Smart Electric Screwdriver

集成扭矩控制、数据记录的 电动拧紧工具



高精度



可追溯



检测准



语音交互



Help enterprises build their own
tightening ecosystem.

产品 展示 Product Showcase



ETC-GH系列

手持有线枪式工具
量程覆盖0.05-30.0 Nm



BTC-WGH系列

手持无线枪式工具
量程覆盖0.3-30.0 Nm



ETC-SH系列

手持式有线直柄工具
量程覆盖0.05-30.0Nm



ETC-AH系列

手持式有线弯头工具
量程覆盖1.0-45.0Nm



BTC-WAH系列

手持式无线弯头工具
量程覆盖1.0-30.0Nm



ETH-AH系列

手持式高压伺服弯头工具
量程覆盖10.0-50.0Nm



HL系列

手持式无线弯头工具
量程覆盖0.05-0.5Nm

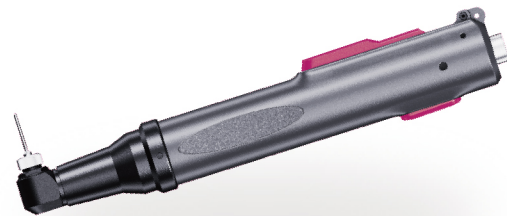

HXL系列

手持式无线弯头工具
量程覆盖0.3-4.8Nm



HDXL系列

手持式无线弯头工具
量程覆盖0.5-25.0Nm



HTXL系列

手持式无线弯头工具
量程覆盖10.0-50.0Nm

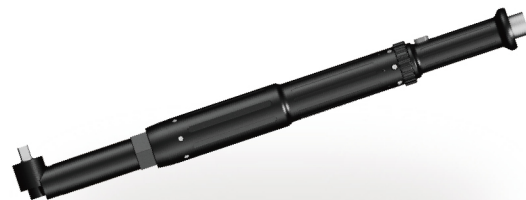

HFXL系列

手持式无线弯头工具
量程覆盖15.0-200.0Nm

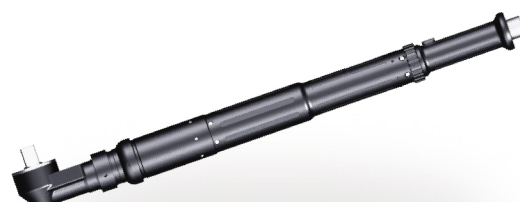

高精度

扭力控制, 扭力精度达到 $\pm 3\% \sim \pm 5\%$;

可追溯

锁付结果数据可显示、可存储可导出可上传MES系统、

免维护

采用高端进口配件, 寿命长免去频繁点检和维修保养

多任务

IO可切换16种任务参数, 每种支持5段和2段拧松步骤

有反馈

浮高/滑牙判断, 状态灯显示语音播报, 有扭力结果反馈

易使用

安装简单, 调试界面简洁, 提供二次开发接口和技术支持



3C电子

微型螺丝精密锁附, 适配轻薄小体积产品, 覆盖整机组装全流程。

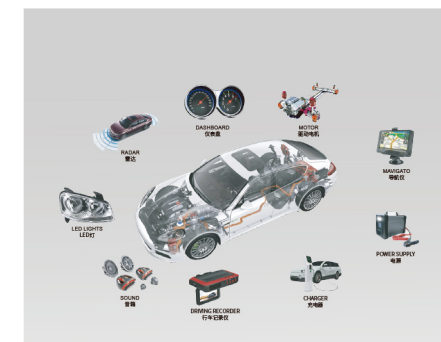

汽车电子

高稳高精抗震动, 适配车载环境, 锁附车内各类电子部件。



白色家电

通用螺丝适配大批量生产, 覆盖整机及核心部件组装, 兼顾自动化产线。

适用范围	M0.6-M20.0的多种螺丝和锁付场景
通讯方式	232、485串口通讯, 以太网口通讯, 总线通讯
异常检测	有浮高滑牙报警检测和防漏防错防呆功能
技术支持	语音, 视频, 电话24小时在线沟通和及时上门服务



自动化智能扭力测试仪

- 实时输出扭力值、扭力峰值等数据
- 即时上传数据至机台管理系统
- 0.5%扭力检测精度, 重复测试稳定性高
- 兼容市场所有电批
- 支持IO口与PLC连接控制
- 兼容RS485、RS232、Ethernet(选配)主流通讯方式通讯, 提供更完整的防错方案

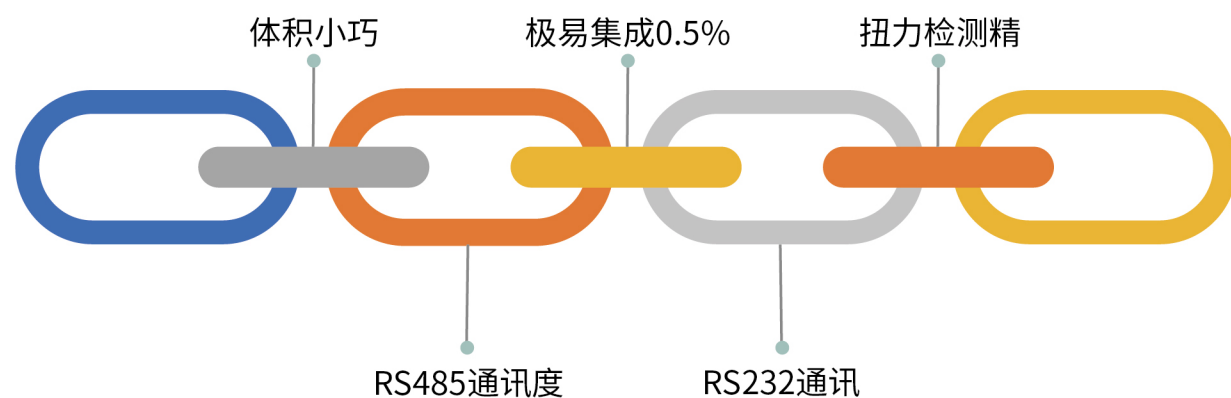

扭力管理系统架构

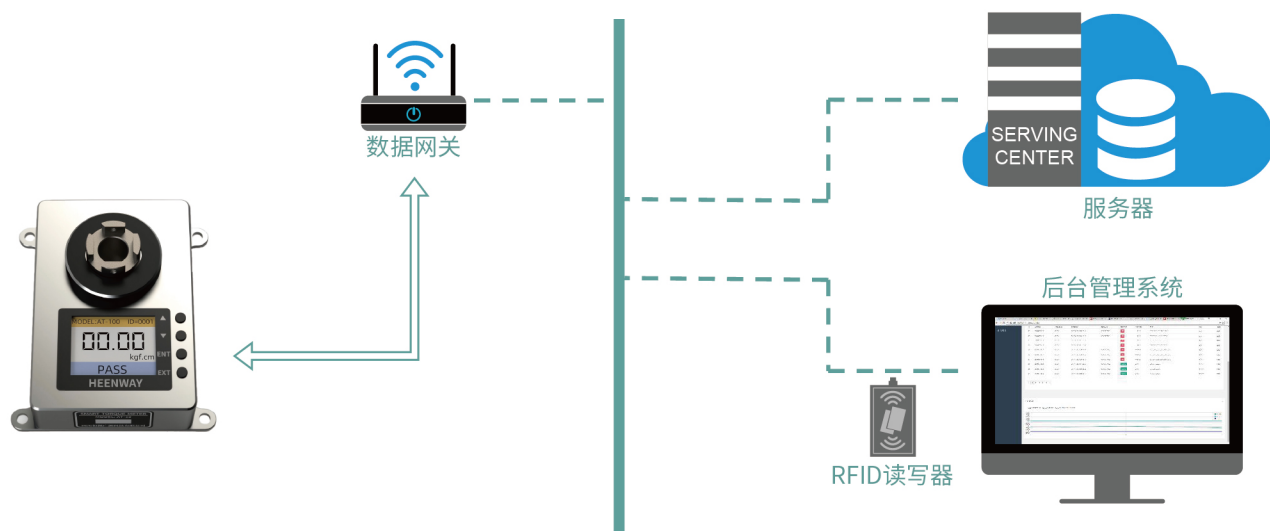

智能定位平衡力臂

- 定制力臂软件系统与智能工具集成, 更高效
- 手动拖拽力臂预设螺钉的位置和顺序
- 实物图上传, 提供更准确的图文提示动态提示
- 需要作业的拧紧点位, 并自动执行预设的拧紧位顺序, 实现绝对防错
- 过程可与扫码枪、供料器、套筒选择器等设备通讯,
- 提供更完整的防错方案

- 省时省力
Time-saving
- 防错降本
Error-proof
- 智能可靠
Intelligent

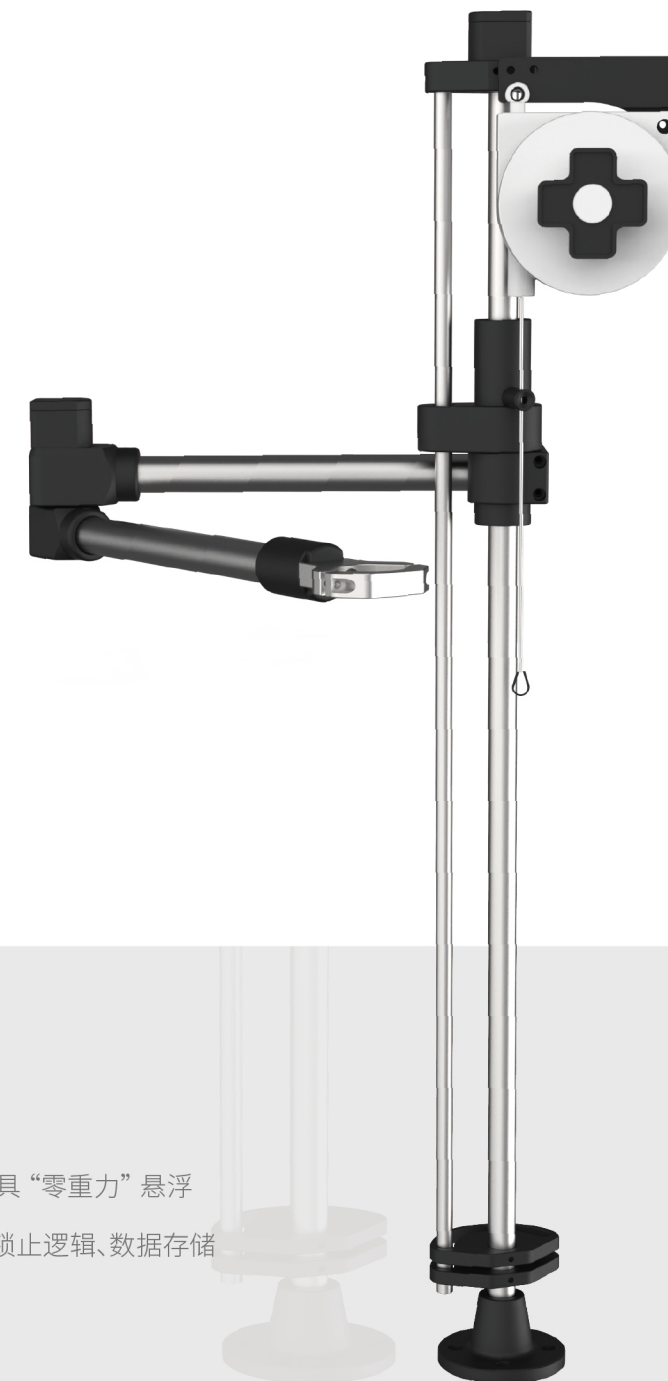

核心结构

机械臂体: 旋转关节 + 直线导轨

传感系统: 旋转编码器、直线编码器

平衡系统: 拉力平衡器 / 气动 / 伺服平衡, 实现工具“零重力”悬浮

控制系统: 定位控制器 + 上位机软件, 预设坐标、锁止逻辑、数据存储

执行端: 智能电批 / 拧紧枪, 受系统控制启停

批头选择器

- 作业员拿起指定批头时, 选择器自动切换对应的Pset, 消除人为失误
- 可作为提示单元, 指导作业员取用正确批头
- 若取错批头, 立即报警, 彻底杜绝异常作业

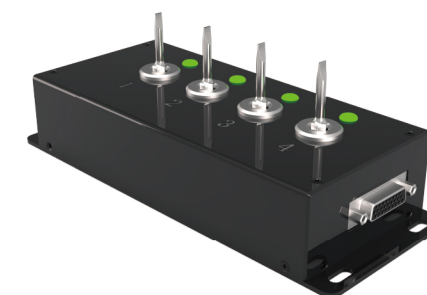

「紧固件」

扫码开盖
6 908372 187003 2

「USB」



总控

「动态跟踪」

检测吹气机构



清洁装置

供钉机

TCP/IP

TCP/IP

TCP/IP

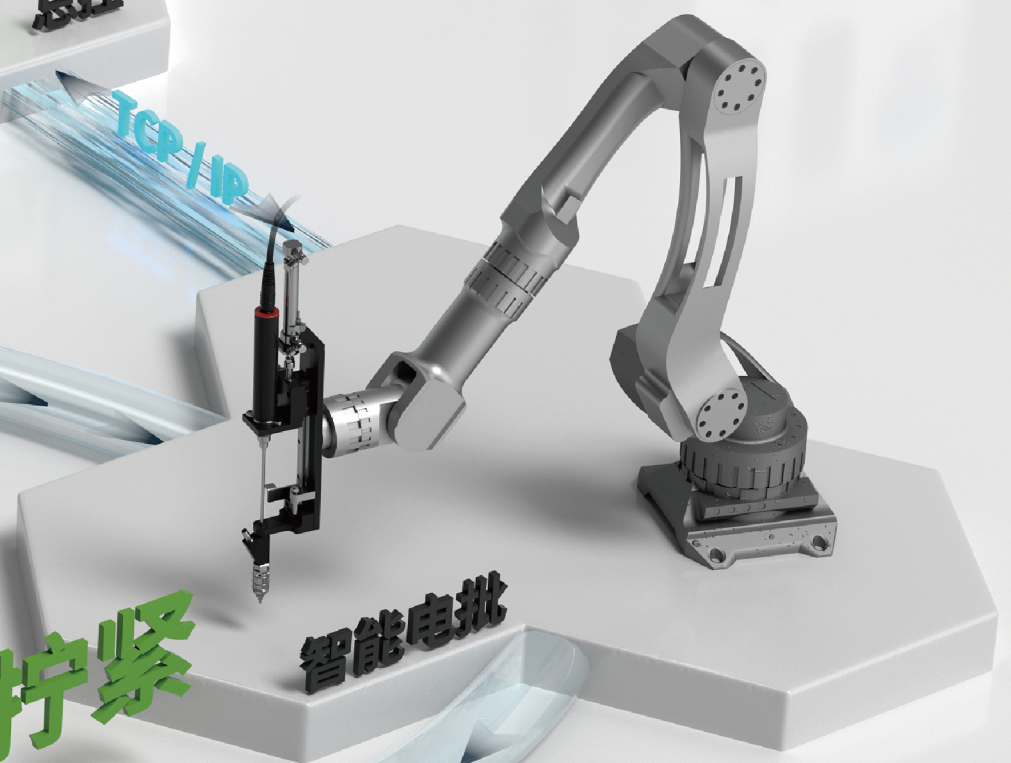

智能电批

「正确拧紧」



合格产品

荣逸智能拧紧
每一步都精准

TONY/保保



智能机用站 助力企业实现无人化拧紧生产

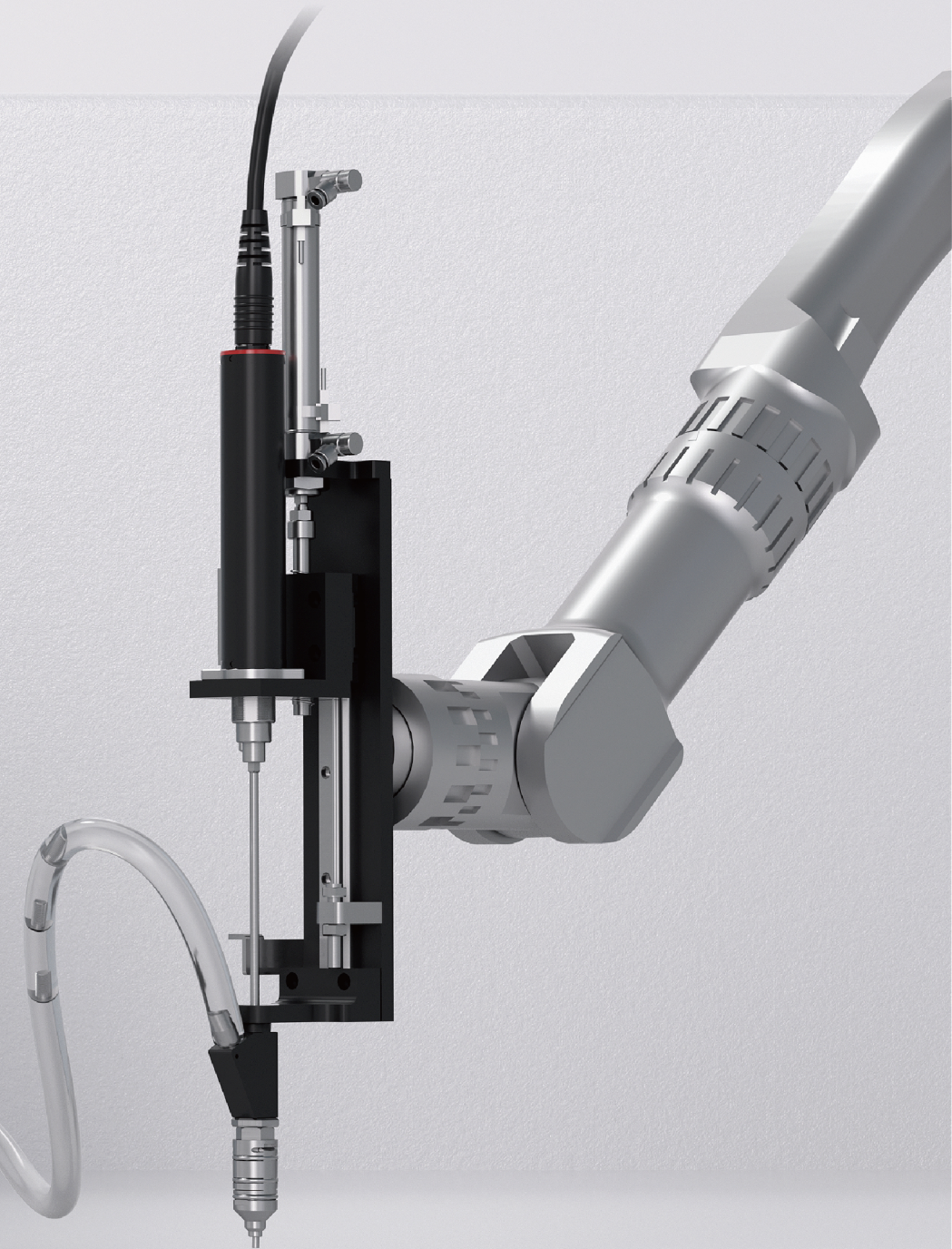
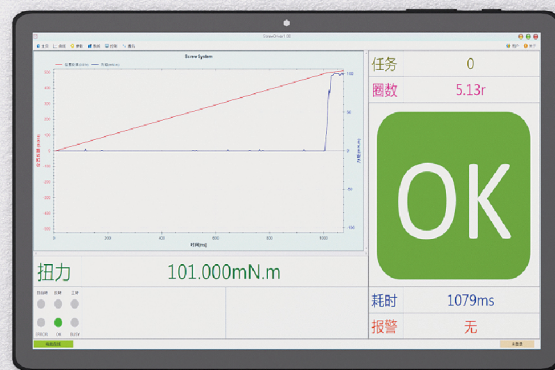

INTELLIGENT MANUAL WORKSTATION

Smart Start





MACHINE STATION SERIES

机用站系列

机用站系列产品:转盘机用式、吹气式供钉机、智能电批、拧紧模组等
MACHINE-MOUNTED TIGHTENING STATION SERIES: ROTARY MOUNTED TYPE, PNEUMATIC SCREW FEEDER, INTELLIGENT ELECTRIC SCREWDRIVER



QJT-200



QJT-350



QJV-60V



QJV-80V

MACHINE-MOUNTED SCREW FEEDER 机用式供钉机



QJW-328



QJW-528



QJW-301S



QJW-221



QJW-728



QJW-160



QJW-190



QJW-160FD



QJW-190FD



QJW-50



QJW-80K



QJW-80KD

BLOW-TYPE SCREW FEEDER 吹气式供钉机



QCW-120



QCW-190FD



QCT-200



QCT-300



QCT-350

SCREW BUFFER BIN 补料仓



QL-001



QL-401



QL-190



机用式供钉机

Machine-Mounted Screw Feeder

自动化批量锁付与 精准供料的核心设备

-  卡钉率低
-  稳定性高
-  操作便捷
-  精度准确



Help enterprises build their own
tightening ecosystem.

产品详情 Product Details



QJW-328

转盘吸附式供钉机

尺寸:长:160 宽:82 高:118mm

(不支持含垫片螺丝)

重量:N.W 1.53KG



平头螺丝



圆头螺丝

帽头

帽头直径 $1.5 \leq D \leq 3$
帽头厚度 $0.3 \leq H \leq 1$

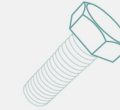

螺牙 (M1.0-M1.7) (M2.0)

螺牙径长 ≤ 5 ≤ 3
螺牙总长 < 6 < 4



范围

M1.0-M2.0

容量

50CC

通讯协议

IO

QJW-528

转盘吸附式供钉机

尺寸:长:182 宽:124 高:145mm

(不支持含垫片螺丝)

重量:N.W 3.1KG



平头螺丝



圆头螺丝



普通内六角螺丝



普通外六角螺丝

帽头

帽头直径 $1.5 \leq D \leq 8$
帽头厚度 $0.3 \leq H \leq 5$

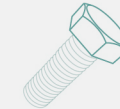

螺牙 (M1.0-M3.0) (M4.0)

螺牙径长 ≤ 12 ≤ 9
螺牙总长 < 15 < 10



范围

M1.0-M4.0

容量

220CC

通讯协议

IO



QJW-301S

转盘吸附式供钉机

尺寸:长:202 宽:126 高:150mm

(不支持含垫片螺丝)

重量:N.W 3.1KG



平头螺丝



圆头螺丝



普通内六角螺丝



普通外六角螺丝

帽头

帽头直径 $1.5 \leq D \leq 8$
帽头厚度 $0.3 \leq H \leq 5$

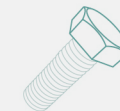

螺牙 (M2.0-M3.0) (M4.0)

螺牙径长 ≤ 12 ≤ 9
螺牙总长 < 15 < 10



范围

M2.0-M4.0

容量

220CC

通讯协议

IO



产品详情 Product Details

QJW-221 转盘吸附式供钉机

尺寸:长:182 宽:123 高:145mm (不支持含垫片螺丝)
重量:N.W 3.5KG



平头螺丝 圆头螺丝 普通内六角螺丝 普通外六角螺丝

帽头	螺牙	
帽头直径 1.5≤D≤8 帽头厚度 0.3≤H≤5	螺牙 (M1.2-M2.0) (M2.3-M4.0) 螺牙径长 ≤8 ≤6 螺牙总长 <10 <8	
范围	容量	通讯协议
M1.2-M4.0	300CC	IO

QJW-160 转盘吸附式供钉机

尺寸:长:263 宽:162 高:178mm (不支持含垫片螺丝)
重量:N.W 5KG



平头螺丝 圆头螺丝 普通内六角螺丝 普通外六角螺丝

帽头	螺牙	
帽头直径 3≤D≤12 帽头厚度 0.3≤H≤7	螺牙 (M2.0-M3.0) (M4.0-M5.0) 螺牙径长 ≤20 ≤15 螺牙总长 <25 <20	
范围	容量	通讯协议
M2.0-M5.0	600CC	IO

QJW-728 转盘吸附式供钉机

尺寸:长:263 宽:162 高:178mm (不支持含垫片螺丝)
重量:N.W 5KG

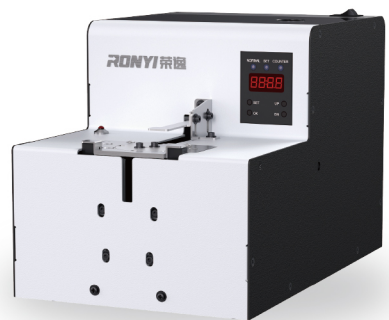

平头螺丝 圆头螺丝 普通内六角螺丝 普通外六角螺丝

帽头	螺牙	
帽头直径 3≤D≤12 帽头厚度 0.3≤H≤7	螺牙 (M2.0-M3.0) (M4.0-M5.0) 螺牙径长 ≤20 ≤25 螺牙总长 <25 <20	
范围	容量	通讯协议
M2.0-M5.0	600CC	IO

产品详情 Product Details

QJW-190 转盘吸附式供钉机

尺寸:长:288 宽:190 高:213mm (不支持含垫片螺丝)
重量:N.W 7KG



平头螺丝 圆头螺丝 普通内六角螺丝 普通外六角螺丝

帽头	螺牙	
帽头直径 3≤D≤15 帽头厚度 0.3≤H≤9	螺牙 (M2.0-M3.0) (M4.0-M6.0) 螺牙径长 ≤25 ≤20 螺牙总长 <30 <25	
范围	容量	通讯协议
M2.3-M6.0	900CC	IO

QJW-160FD 转盘吸附式供钉机

尺寸:长:323 宽:163 高:279mm (不支持含垫片螺丝)
重量:N.W 8KG



平头螺丝 圆头螺丝 普通内六角螺丝 普通外六角螺丝

帽头	螺牙	
帽头直径 2≤D≤12 帽头厚度 1≤H≤7	螺牙 (M2.0-M3.0) (M4.0-M5.0) 螺牙径长 ≤20 ≤15 螺牙总长 <25 <20	
范围	容量	通讯协议
M2.0-M5.0	600CC	IO/485

QJW-190FD 转盘吸附式供钉机

尺寸:长:323 宽:190 高:290mm (不支持含垫片螺丝)
重量:N.W 9KG



平头螺丝 圆头螺丝 普通内六角螺丝 普通外六角螺丝

帽头	螺牙	
帽头直径 5.5≤D≤15 帽头厚度 2≤H≤10	螺牙 (M3.0-M6.0) 螺牙径长 ≤25 螺牙总长 <28	
范围	容量	通讯协议
M3.0-M6.0	900CC	IO/485



产品详情 Product Details

QJW-50

转盘吸附式供钉机

尺寸:长:234 宽:50 高:163mm
重量:N.W 2KG

(不支持含垫片螺丝)

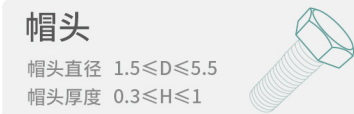

范围	容量	通讯协议
M1.0-M2.0	60CC	IO



QJW-80K

转盘吸附式供钉机

尺寸:长:156 宽:82 高:134mm
重量:N.W 1.8KG

(不支持含垫片螺丝)

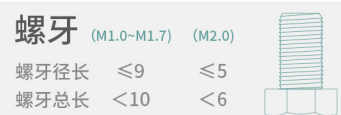
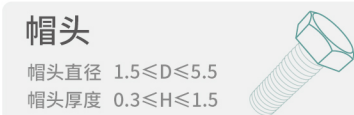

范围	容量	通讯协议
M1.0-M2.0	60CC	IO



QJW-80KD

转盘吸附式供钉机

尺寸:长:159 宽:81 高:106mm
重量:N.W 1.8KG

(不支持含垫片螺丝)

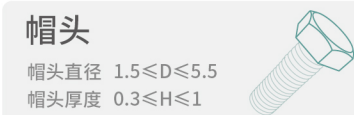

范围	容量	通讯协议
M1.0-M2.0	50CC	IO



产品详情 Product Details

QJT-200

推举式机用供钉机

尺寸:长:390 宽:200 高:352mm
重量:N.W 20KG



范围	容量	通讯协议
M2.0-M6.0	1000CC	IO/485



QJT-300

推举式机用供钉机

尺寸:长:390 宽:300 高:352mm
重量:N.W 25KG



范围	容量	通讯协议
M2.0-M6.0	2000CC	IO/485



QJT-350

推举式机用供钉机

尺寸:长:470 宽:350 高:445mm
重量:N.W 40KG



范围	容量	通讯协议
M3.0-M10.0	3000CC	IO/485



机用式供钉机

MACHINE-MOUNTED SCREW FEEDER

- 卡钉率低
- 稳定性高
- 操作便捷
- 精度准确



QJV-60V 无轨吸附式供钉机

尺寸:长:140 宽:60 高:101mm
重量:N.W 1.1KG

- 平头螺丝
- 圆头螺丝

帽头	螺牙
帽头直径 $1.5 \leq D \leq 4$ 帽头厚度 $0.3 \leq H \leq 1.5$	(M0.8-M1.4) 螺牙径长 ≤ 2.5 螺牙总长 < 4

范围	容量	通讯协议
M0.8-M1.4	30CC	IO



QJV-80V 无轨吸附式供钉机

尺寸:长:140 宽:82 高:105mm
重量:N.W 1.4KG

- 平头螺丝
- 圆头螺丝

帽头	螺牙
帽头直径 $1.5 \leq D \leq 4$ 帽头厚度 $0.3 \leq H \leq 1.5$	(M0.8-M1.7) 螺牙径长 ≤ 3.5 螺牙总长 < 5

范围	容量	通讯协议
M0.8-M1.7	60CC	IO



上料流程 Feeding Process

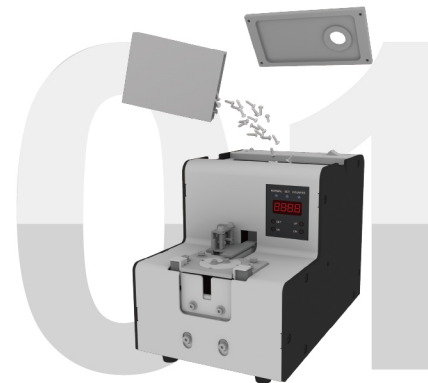

放置螺钉

取下上盖, 观察是否有异物, 将螺丝放入料槽室内, 至轨道下沿1-2mm。

分料定位

单颗有序输送至转盘取料位, 卡槽精准卡位固定螺丝, 确保取料位置统一。

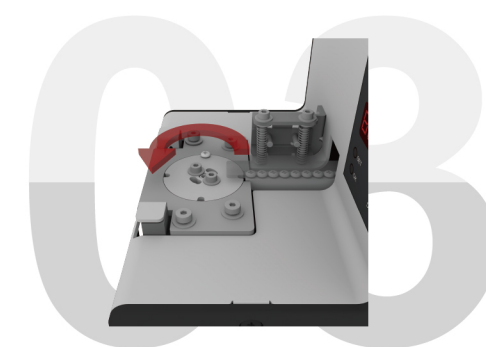
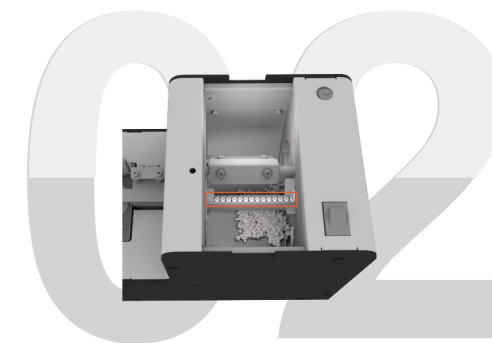

出料待取

定位后的螺丝稳定停留在取料位, 无偏移、无滑落, 处于机械臂可直接抓取的待作业状态。

取料锁付

机械臂移动至取料位, 对准已定位的螺钉头部完成吸附。



产品优势 Product Advantages

适用性广

- 适用多种螺钉尺寸
- 长径比 ≤ 1 也可适用



卡钉率低

- 筛料装置独立驱动
- 异常姿态螺钉高效筛除

0.02%

定位精准

- 十字槽轮机构驱动
- 到位后结构锁死
- 重复定位精度 ± 0.05



防呆防错

- 扫码开盖防止错误加料



故障率低

- 直流无刷电机
- 保证设备稳定运行



灵活调整

- 可视化参数设置界面
- 中文显示



高效送料

- 四分度转盘单颗分料
- 送料速度1-1.5S/颗



功能多样

- 多种扩展功能模块:
- 缺料/满料检测, 螺钉清洁等



适用机型 Applicable Models

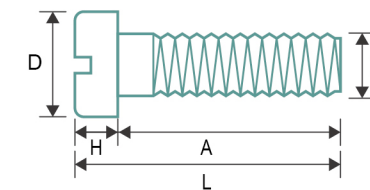

螺钉范围	料仓容量	产品型号	出料方式	电源V/Hz
M0.8-M1.4	30cc	QJV-60V	转盘式	240V/50Hz
M0.8-M1.7	60cc	QJV-80V		
M1.0-M2.0	60cc	QJW-50		
M1.0-M2.0	60cc	QJW-80K		
M1.0-M2.0	50cc	QJW-80KD		
M1.0-M2.0	50cc	QJW-328		
M1.0-M4.0	220cc	QJW-528		
M1.2-M4.0	300cc	QJW-221		
M2.0-M4.0	220cc	QJW-301S		
M2.0-M5.0	600cc	QJW-728、QJW-160		
M2.3-M6.0	900cc	QJW-190		
M2.0-M5.0	600cc	QJW-160FD		
M3.0-M6.0	900cc	QJW-190FD		
M2.0-M6.0	1000cc	QJT-200		
M2.0-M6.0	2000cc	QJT-300		
M3.0-M10.0	3000cc	QJT-350		

* 上述为参考值, 实际适配螺钉规格请与我司技术支持沟通, 且超出范围的螺钉可以提供样钉进行测试

产品结构 Product Structure

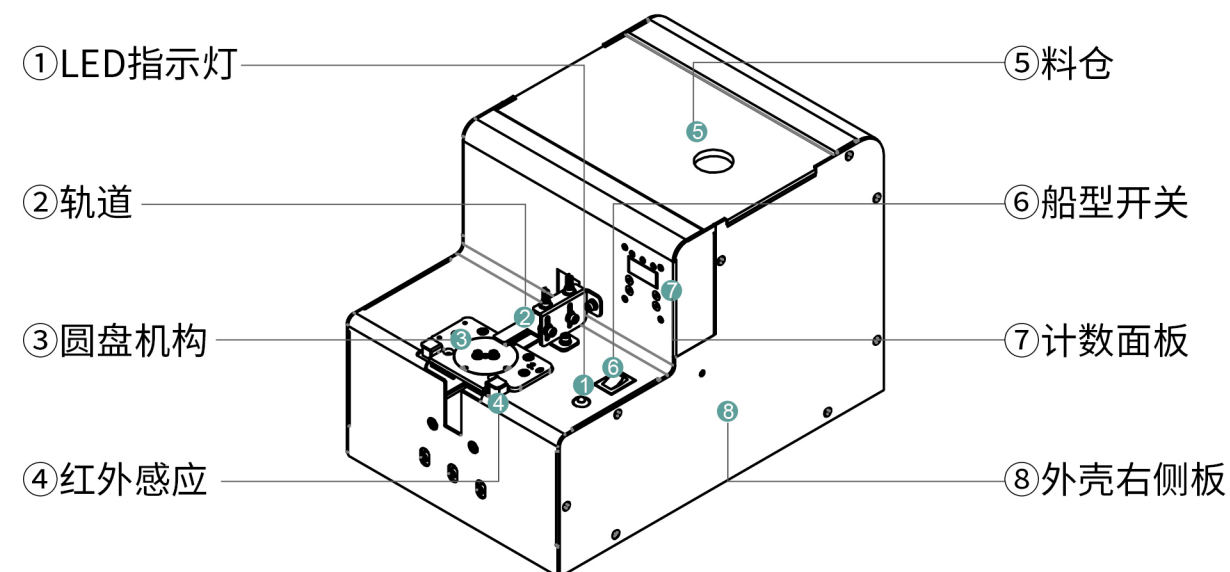

吹气式供钉机

Blow-Type Screw Feeder

由机械臂执行锁付 实现柔性定位的核心设备

-  卡钉率低
-  稳定性高
-  操作便捷
-  精度准确



Help enterprises build their own
tightening ecosystem.

产品详情 Product Details



QCW-120

滚筒式吹气供钉机

尺寸:长:338 宽:124 高:240mm

(不支持含垫片螺丝)

重量:N.W 6KG

-  平头螺丝
-  圆头螺丝
-  普通内六角螺丝
-  普通外六角螺丝

帽头	螺牙
帽头直径 $1.5 \leq D \leq 6$ 帽头厚度 $0.3 \leq H \leq 3$	螺牙径长 ≤ 8 螺牙总长 < 10

范围	容量	通讯协议
M1.7-M2.0	300CC	IO



QCW-190FD

滚筒式吹气供钉机

尺寸:长:355 宽:190 高:290mm

(不支持含垫片螺丝)

重量:N.W 10KG

-  平头螺丝
-  圆头螺丝
-  普通内六角螺丝
-  普通外六角螺丝

帽头	螺牙
帽头直径 $5.5 \leq D \leq 12$ 帽头厚度 $2 \leq H \leq 10$	螺牙径长 ≤ 20 螺牙总长 < 30

范围	容量	通讯协议
M3.0-M6.0	900CC	IO/485



QCT-200

推举式吹气供钉机

尺寸:长:390 宽:200 高:352mm

(不支持含垫片螺丝)

重量:N.W 20KG

-  平头螺丝
-  圆头螺丝
-  普通内六角螺丝
-  普通外六角螺丝

帽头	螺牙
帽头直径 $3 \leq D \leq 13$ 帽头厚度 $2 \leq H \leq 9$	螺牙径长 ≤ 40 螺牙总长 < 49

范围	容量	通讯协议
M2.0-M6.0	1000CC	IO/485



吹气式供钉机

BLOW-TYPE SCREW FEEDER

- 卡钉率低
- 稳定性高
- 操作便捷
- 精度准确



QCT-300 推举式吹气供钉机

尺寸:长:390 宽:300 高:352mm
重量:N.W 25KG
(不支持含垫片螺丝)

- 平头螺丝
- 圆头螺丝
- 普通内六角螺丝
- 普通外六角螺丝

帽头		螺牙	
帽头直径 $3 \leq D \leq 13$ 帽头厚度 $2 \leq H \leq 9$		螺牙径长 ≤ 40 螺牙总长 < 49	

范围	容量	通讯协议
M2.0-M6.0	2000CC	IO/485



QCT-350 推举式吹气供钉机

尺寸:长:470 宽:350 高:445mm
重量:N.W 40KG
(不支持含垫片螺丝)

- 平头螺丝
- 圆头螺丝
- 普通内六角螺丝
- 普通外六角螺丝

帽头		螺牙	
帽头直径 $3 \leq D \leq 13$ 帽头厚度 $2 \leq H \leq 10$		螺牙径长 ≤ 60 螺牙总长 < 69	

范围	容量	通讯协议
M3.0-M10.0	3000CC	IO/485



上料流程 Feeding Process



加料上料

将螺丝倒入料仓, 不超过输送轨道高度, 启动设备, 让螺丝自动排列至分料口。

整序筛选

推举上料, 螺丝沿轨道单颗同向排列, 毛刷剔除不良姿态螺丝, 传感器监控料况。

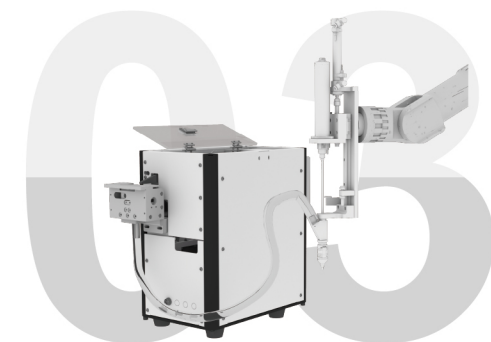

分料吹送

启动供料开关, 螺丝经吹气输送至批嘴, 无卡顿、分料机构单次分离 1 颗螺丝, 精准定位吹气口。

锁付作业

设备自动供钉、锁附, 完成后自动续料, 全程观察供料稳定性, 及时处理异常。

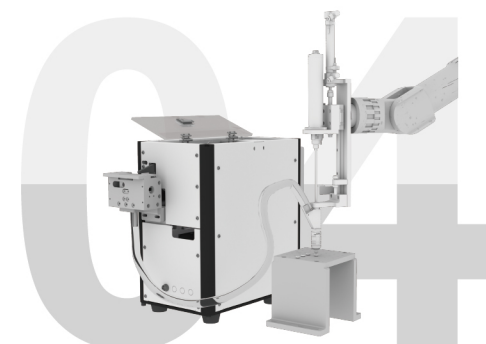

产品优势 Product Advantages

适用性广

- 适用多种螺钉尺寸
- 长径比 ≤ 1 也可适用



清洁上料

- 采用阶梯式推板上料
- 减少螺钉摩擦产生碎屑



更大容量

- 多种料仓容量
- 可供螺钉容纳



防呆防错

- 扫码开盖防止错误加料



稳定性高

- 定制化配件
- 更适配物料特性



快速复原

- 送料位置可视
- 无遮挡, 便于维护



功能多样

- 多种扩展功能模块:
- 缺料/满料检测, 螺钉清洁等



灵活操作

- 轻量化设计
- 体积紧凑不挡视线



适用机型 Applicable Models

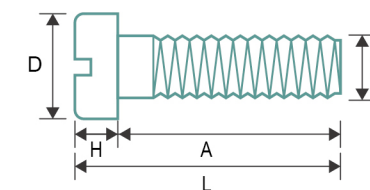

螺钉范围	料仓容量	产品型号	出料方式	电源V/Hz
M1.7-M2.0	300cc	QCW-120	吹气式	240V/50Hz
M3.0-M6.0	900cc	QCW-190FD		
M2.0-M6.0	1000cc	QCT-200		
M2.0-M6.0	2000cc	QCT-300		
M3.0-M10.0	3000cc	QCT-350		

* 上述为参考值, 实际适配螺钉规格请与我司技术支持沟通, 且超出范围的螺钉可以提供样钉进行测试

产品结构 Product Structure

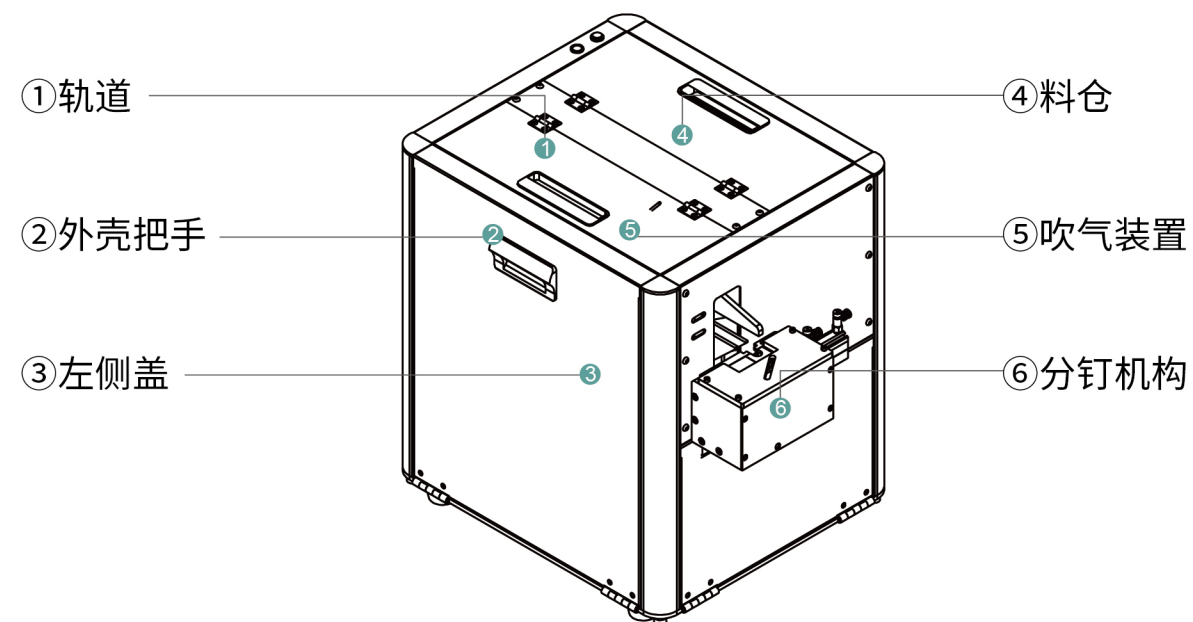

补料仓

Screw Buffer Bin

智能感应自动向供钉机 补料的核心设备

-  卡钉率低
-  稳定性高
-  操作便捷
-  精度准确



Help enterprises build their own
tightening ecosystem.

产品详情 Product Details



QL-001

螺丝补料仓

尺寸:长:147 宽:125 高:209mm
重量:N.W 1.8KG

帽头 帽头直径 $D \leq 10$ 帽头厚度 $H > 1.5$		螺牙 (M2.0-M6.0) 螺牙径长 ≥ 2 螺牙总长 < 25	
范围 M2.0-M6.0	容量 600CC		



QL-401

螺丝补料仓

尺寸:长:173 宽:163 高:240mm
重量:N.W 3KG

帽头 帽头直径 $D \leq 10$ 帽头厚度 $H > 1.5$		螺牙 (M2.0-M6.0) 螺牙径长 ≥ 2 螺牙总长 < 25	
范围 M2.0-M6.0	容量 800CC		

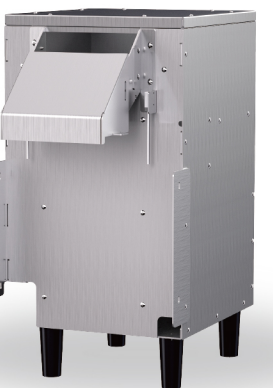

QL-190

螺丝补料仓

尺寸:长:294 宽:190 高:341mm
重量:N.W 5KG

帽头 帽头直径 $D \leq 15$ 帽头厚度 $H > 1.5$		螺牙 (M2.0-M6.0) 螺牙径长 ≥ 2 螺牙总长 < 50	
范围 M2.0-M8.0	容量 1500CC		

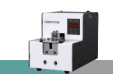

800+

合作伙伴

选择与荣逸同行——共同打造
自己的拧紧生态

Choose to walk with Rongyi — Co-build
your own tightening ecosystem.

